

PDS GANTRY ROBOT

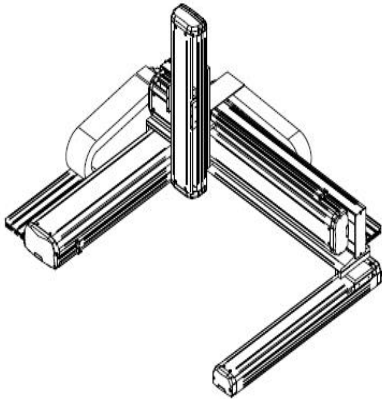

	PDS-DT-331GS	PDS-DT441GS	PDS-DT551GS	PDS-DT-661GS
Working range X-Y in mm	300x300	400x400	500x500	600x600
Height Z axis	100	100	100	100
Load Y -Z axis	30kg /10kg			
X-Y-Z (mm/sec)	0,1-500/200			
Resolution	0,01mm/axis			
Repetitive Positioning Accuracy	+/- 0,002mm / axis			
Programm capacity	100 programmes 4000 points/programm			
Programm Display	Teach pendant LCD			
Motor system	AC servo motor			
Control method	PTP & CP			
Interpolation Function	3 axis (3D path)			
Progamation method	Teach Pendant			
I/O Signals port	8 Inputs / 8 Outputs			
External control Interface	RS232			
Power supply	AC 220v - 500W			
Working temperature	10°C - 40°C			
Working relative Humidity	20% - 90% no condensation			
Dimensions (WxDxH)mm	650x750x550	750x850x550	850x950x550	50x105x550
Robot Weight	60kg	70kg	80kg	90kg

This document is not contractual